



CAMEC® Picnic Table

**NEW
RELEASE**



- Suit most RV vehicles
- Australian made
- Externally mounted
- Size: W800mm x H450mm x D40mm
- Lockable fold down table
- Stainless steel stays and hinges
- Maximum load 20kg
- Camec One Key Fits All barrel housing
- Easy clean surface
- Easy to install

Parts included in kit:

- A.** 12 off 8 gauge button head screws
- B.** 12 off 5-3 aluminium rivets
- C.** 12 off 3/16 bulbex rivets
- D.** Foam tape
- E.** Plastic back plate
- F.** Folding table panel

PART NO. 040261

 **CAMEC**® | GO FURTHER

Camec New South Wales
Unit 1, 2 Garner Pl, Ingleburn NSW 2565
P: 02 8706 0888
F: 02 8706 0899

Camec Queensland
Building 3, Archerfield Industrial Park
Cnr Kerry & Beaudesert Rds,
Archerfield QLD 4108
P: 07 3710 9000
F: 07 3710 9011
E: enq@qld.camec.com.au

Camec Victoria
47-63 Remington Dr,
Dandenong South VIC 3175
P: 03 9799 6455
F: 03 9799 6466
E: camec@camec.com.au

Camec Western Australia
190 Welshpool Rd,
Welshpool WA 6106
P: 08 9351 0000
F: 08 9351 0030
E: sales@wa.camec.com.au

283A Kingsway, Caringbah NSW 2229
P: 02 9525 2588
F: 02 9526 6230
E: enqnsww@camec.com.au

www.camec.com.au

Camec Picnic Table Fitting Instructions. Please ensure all power has been turned off to the vehicle before drilling any holes.

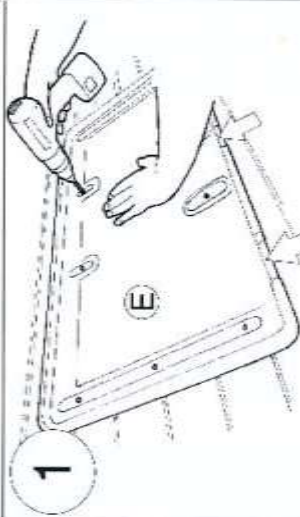

1 Establish position for mounting back panel. Ensure cut out hinge areas are on base edge. Drill 4mm holes approximately as per layout shown in mounting plate, placing a rivet in the first hole to align before drilling second hole. Do not rivet yet!
 Note: If drilling into timber drill 3mm hole if riveting to sheet metal drill 5mm hole.

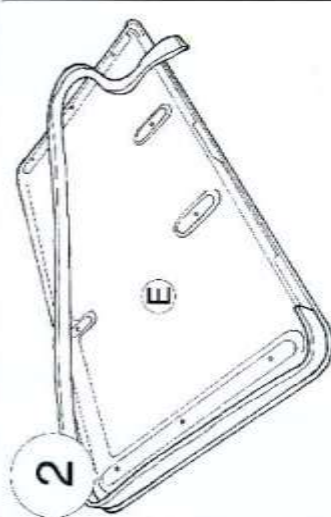

2 Turn back panel over and fit foam tape to outer channel area starting from base hinge area, around top and finish at hinge cut out on other side.

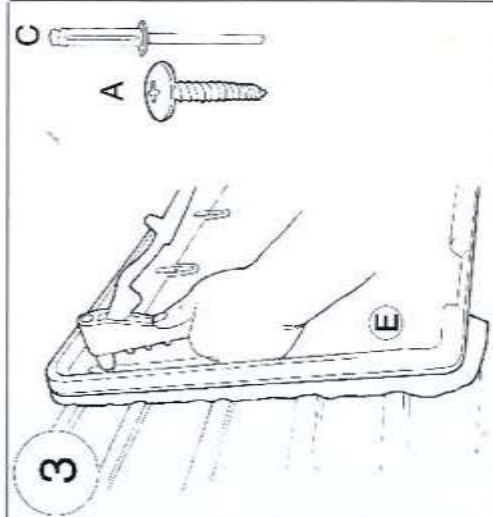

3 Place back panel on wall and fix through one corner hole into pre-unked holes in mounting location. Ensure foam tape is fitting before proceeding to final holes.
 Note: if you have timber to locate into, use supplied screws instead of larger kit rivets. Do not over tighten screws!

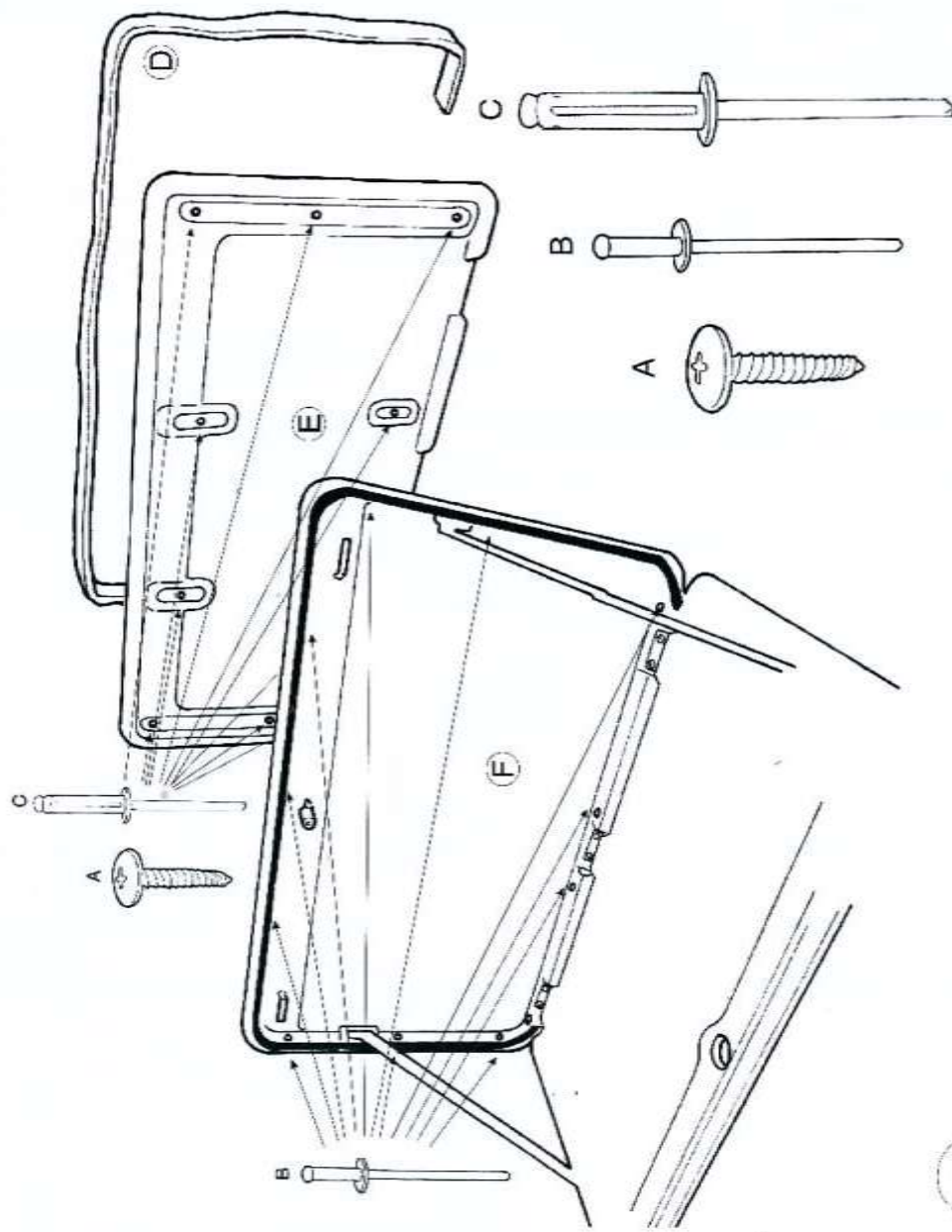

4 Once back panel is fitted in position, with foam tape located, place fold down table onto it. Ensure lock is at top and units fit together without any distortion. Open fold down panel and pre-drill through holes in side flange with 4mm drill bit. Caution should be taken to only drill through table panel flange and mounting panel on inner side and do not drill through outer skin.

Tools required:-

- A. 3mm drill (to drill holes for 8 Gauge x 20mm Button Head Screws if fixing into timber).
- B. 4mm drill (to drill holes for 5-3 Aluminium Pop Rivets to Hold the Picnic Table to the Back Plate).
- C. 5mm drill (to drill holes for 3/16" diam Avdel Bulbex Rivets (P/No 08F4-1-00625) to hold the Back Plate to the Aluminium Cladding).
- D. Power drill.
- E. Phillips head driver.
- F. Pop Rivet Gun.

Parts included in kit:-

- A. 12 off 8 Gauge button head screws
- B. 12 off 5-3 aluminium rivets
- C. 12 off 3/16 bulbex rivets
- D. Foam tape
- E. Plastic back plate
- F. Folding table panel